



**65TM**

 **Kawasaki**



# 65<sup>TM</sup>

## A COMPLETE SOLUTION

- Emissions-compliant, fuel-efficient 134 HP Cummins diesel
- 2.6 cu. yard to 2.8 cu. yard buckets available
- Accepts a wide assortment of attachments to handle many jobs
- Ride Control option provides stable load handling
- Single hydraulic control, standard, improves cycle times and ease of operation
- Automatic powershift transmission with four forward and reverse speeds
- Transmission designed with helical gears, reducing noise level and vibration
- Inboard-mounted, four-wheel, dual circuit sealed wet disc brakes for reliability and long service life
- Torque-proportioning differentials for improved traction and longer tire life
- Easy access to drains, filters and fittings
- Engine cooling system with hydraulic fan for efficient cooling

## THE POWER TO PERFORM!

With the Kawasaki **65<sup>TM</sup>**, a single loader can accomplish a wide range of tasks on the job site. From moving dirt with the general purpose bucket to backfilling with the side dump bucket, handling pipe with the forks or manhole and cement pipe junction placement with the boom, the Kawasaki **65<sup>TM</sup>** offers versatility to handle many jobs without the need for multiple machines.

Featuring a fuel efficient, emissions-compliant Cummins 6BTAA5.9 diesel engine producing 134 flywheel horsepower, a Quick Coupler, parallelogram lift arm linkage and third hydraulic spool option, the Kawasaki **65<sup>TM</sup>** TaskMaster is a natural choice for companies needing a truly versatile, multi-mission machine. The **65<sup>TM</sup>** provides high operating efficiency, ease of maintenance and safety.

## OPERATOR PRODUCTIVITY AND SAFETY

The **65<sup>TM</sup>** features a completely redesigned ROPS cab with an operator's compartment that offers unmatched comfort and is designed to maximize efficiency and productivity. The cab is accessible by ladders on both sides, features a gasket-mounted flat tinted glass windshield, has front and rear wipers and includes many other features which contribute to improved safety, visibility and comfort. The **65<sup>TM</sup>** comes standard with an AM/FM cassette player and can even be ordered with an optional 27,000 BTU air conditioner.



*Kawasaki and their dealer organization offer comprehensive support and service programs designed to keep you on the job.*

### **PUTTING THE 65™ TO WORK**

Like all Kawasaki loaders, the 65™ has a 40-year heritage of strength and reliability. Single lever hydraulic control with a dual lever option and single twist-grip transmission control offer ease of operation.

The 65™ is available with a 2.6 cubic yard bucket with a bolt-on cutting edge. A third spool valve, control lever, linkage and line are available to handle a number of attachments and extend the 65™'s versatility. A full range of buckets, Quick Couplers and attachments are also available.

The inboard-mounted, four-wheel sealed wet disc brakes are designed for long life and high capacity. Standard spin-on filters, remote mounted grease fittings and oil drain simplify maintenance. The standard 20.5 x 25 tires and optional 17.5 x 25 12PR tires use heavy duty rims.

### **UNMATCHED SUPPORT**

Kawasaki maintains a large inventory of new components to ensure outstanding parts availability and minimal downtime. In addition, a predictive oil analysis program helps eliminate unnecessary maintenance and helps find problems before they occur. Kawasaki also stocks an array of cost-effective rebuilt components.



### **BUILT TO STAY ON THE JOB**

Kawasaki loaders are designed with the durability to provide years of service. Backed by a dealer network of heavy equipment experts and a dedicated support staff in the Kawasaki parts and service organization, your investment in a Kawasaki loader is an excellent choice that will pay dividends for years to come.



# POWER AND PERFORMANCE PROVIDE UNMATCHED PRODUCTIVITY

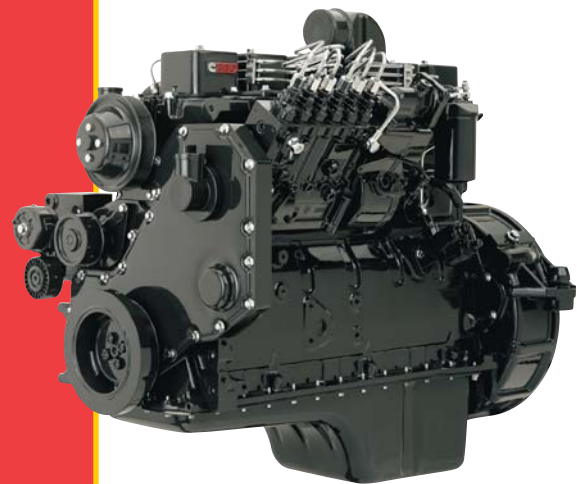

The Kawasaki **65™** means business. It incorporates the best in design and technology, giving your operators the tool they need to get the job done.

Because Kawasaki specializes in the design and manufacture of articulated wheel loaders, you get a machine with a 40-year heritage of successful innovations. The power and productivity that the **65™** brings to the job is a result of that experience.

## WORLD-CLASS ENGINES

- 134 HP fuel efficient, emissions-compliant Cummins 6BTAA5.9 diesel
- Complies with tough Tier 2 emissions standards
- Engineered for longer service life
- Extensive distribution system
- 24 volt battery system for reserve power
- Turbocharger with aftercooler

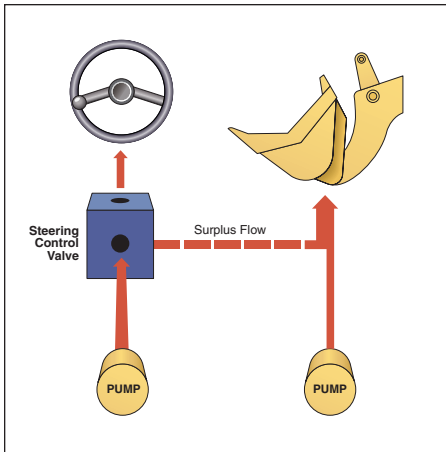

## HIGH EFFICIENCY HYDRAULIC SYSTEM

- Dry, reliable
- Cast iron gear pumps
- Energy efficient, steering circuit supplements main
- Easy access to two-spool control valve
- Large oil reservoir keeps oil cooler



## TRANSMISSION

- Automatic four-speed transmission with powershift
- Single lever control
- Switch activates transmission declutch on right and left brake pedals
- Downshift button speeds cycle times and reduces operator fatigue

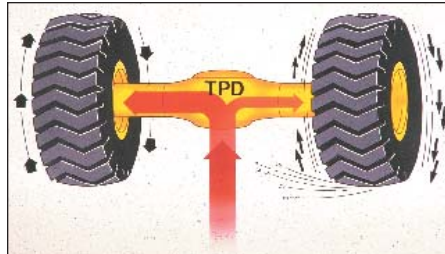

## AXLES/BRAKES

- Heavy-duty torque proportioning differential
- 20.5 x 25-12PR (L-2) tires standard
- 17.5 x 25-12 PR (L-2, L-3 and radial) tires available
- Inboard-mounted, four-wheel, dual-circuit wet disc brakes
- Easy maintenance

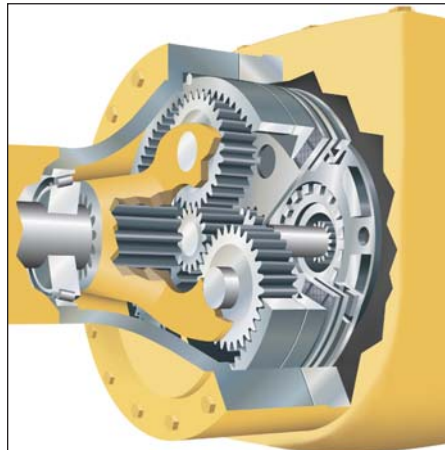

## LIFT ARMS/BUCKETS

- Parallel lift arms keep loads level throughout the lift cycle
- Heaviest in the class
- High breakout force



## STRONG, RUGGED BOX FRAME

- Massive center pins and bearings
- High strength loader tower
- Heavy box frame rear chassis
- All pins of the loading system are fully sealed with grease to provide dependable service with minimum maintenance

# THE COMFORT ZONE



*Kawasaki has taken a from-the-ground-up approach to create a cab designed with the operator in mind. The cab focuses on providing the ultimate environment for productivity, comfort and safety. The high visibility, quiet, temperature controlled cab offers the operator ideal surroundings for putting the Kawasaki loader through its paces.*

## **65™ Features**

- Flat glass windows for easy replacement
- Cab offers easy entry from either side
- Sliding side windows
- Automotive door locks
- Halogen headlights improve nighttime visibility
- Reduced noise level
- Single lever hydraulics
- Cab interior increased 20% in size for operator comfort
- Air Ride Seat
- Telescoping and tilting steering wheel
- Flooring configuration reduces sound levels and allows easy cleaning
- Increased storage
- Climate controlled storage box for food & beverage storage

## **Standard Features**

- All systems monitored with lights and alarms
- Single twist grip transmission lever redesigned for easy gripping and smoother shifting
- Adjustable wrist rest
- One rearview and two side mirrors
- AM/FM cassette radio, standard
- Viscous isolation-mounted to reduce vibration
- Reduced sound levels
- Personal storage space and coat hook
- 40,000 BTU heater, standard
- Cold start feature
- Rear light package
- Pressurized air control
- Switch activates transmission declutch on both brake pedals
- Front and rear wipers and washers
- Intermittent front wiper

## **Options**

- 27,000 BTU Air Conditioner
- Dual lever hydraulic control
- Turn signal with 4-way flasher
- Third spool hydraulic



# EASY ACCESS SIMPLIFIES SERVICING

- Engine side covers open wide for optimum access
- Filters positioned within easy reach
- Easy access to drains, filters and fittings
- Grease fittings are grouped for easy lubrication
- Readily available Fleetguard and Donaldson filters
- Starters and alternators available through Cummins national distribution network
- Cooling system engineered to allow easy access to radiator and hydraulic coolers from side compartments
- Ladders on both sides of the machine
- Pressurized air control reduces dust in cab
- Trunion grease fittings located near axle
- Sealed universal joints (only require greasing at 2000 hour intervals)
- Electric wiring color-coded and numbered for ease of service
- Deutsch electric connectors throughout wiring harness

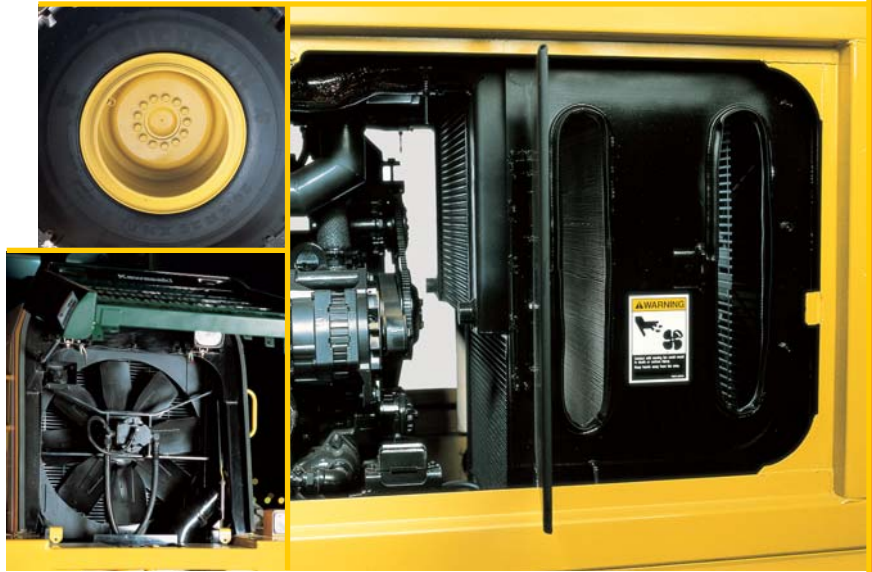

## OPTIONS

### PARALLEL LIFTING CAPABILITY



The parallelogram linkage allows the attachment to remain level throughout the lift cycle, making the **Z** ideal for fork handling and boom applications.

### QUICK COUPLER ATTACHMENT

The JRB Quick Coupler, can be used in conjunction with a variety of attachments, including:

- General purpose buckets
- Side dump bucket
- Construction utility forks
- Utility pallet forks
- Extendable boom
- Paddle top clamp forks
- Grapple bucket
- Loader rake and loader rake with hydraulic clamps

### K-LINK

- On demand reports provide machine location, hours, operating status
- Alarm notification by phone or pager can indicate equipment failure, low-fuel, geo-fence break
- Worldwide satellite coverage
- Customize reports and alerts
- Internet access to all reports and alerts

### RIDE CONTROL

- Stable load handling
- Reduces operator fatigue
- Cuts vibration and equipment wear
- Improves safety and productivity
- Less spillage
- Faster travel speed

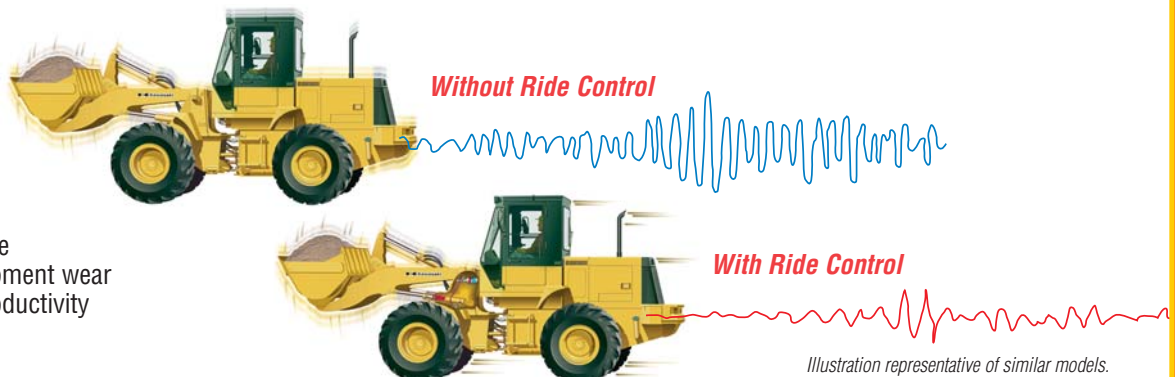

Illustration representative of similar models.

# OPERATING SPECIFICATIONS

ENGINE	
Make/Model/Fuel Type	Cummins/6BTAA5.9/Diesel
Type	4-cycle, watercooled, in-line direct injection type, with turbocharger and air-cooled intercooler
Net flywheel horsepower	134HP/2200 RPM
Max torque	401 ft/lb (55.9kgm)/1500 RPM
Number of cylinders	6
Bore and stroke	4.02" x 4.72" (102mm x 120mm)
Total displacement	359 in <sup>3</sup> (5890 cm <sup>3</sup> )
Alternator	DC24V-1.2KW (50amp)
Starting motor	24V-4.0kw (5.4HP)
Battery	12V-110AH, 2 units
Governor	All-speed, mechanical type

TORQUE CONVERTER AND TRANSMISSION	
Torque converter	3 elements, single stage
Torque stall ratio	3.32:1
Main clutches	Wet hydraulic, multi-disc type
Cooling method	Forced circulation type
Transmission	Full power shift, 4 forward, 4 reverse with automatic mode (2nd-4th) with downshift switch for 2nd-1st downshifting
Forward & reverse (maximum speed)	1st: 5.3 MPH (8.5 km/hr) 2nd: 8.6 MPH (13.9 km/hr) 3rd: 13.7 MPH (22.0 km/hr) 4th: 24.7 MPH (39.7 km/hr)

SERVICE REFILL CAPACITY		
LOCATION	Gallons	Liters
Engine (coolant)	11.4	(43.0)
Fuel tank (diesel fuel)	58.6	(222.0)
Engine oil (oil pan)	4.2	(16.0)
Front axle (gear oil)	6.6	(25.0)
Rear axle (gear oil)	6.6	(25.0)
Torque converter and transmission (engine oil)	7.9	(30.0)
Hydraulic system including tank (hydraulic oil)	26.4	(100.0)

HYDRAULIC AND STEERING SYSTEM		
Steering type	Articulated frame steering	
Steering mechanism	Hydraulic power steering unit, pilot operated type	
Lift (boom) cylinder	Two (2) double-acting piston type: 4.7" x 28.7" (120mm x 730mm)	
Tilt (bucket) cylinder	Two (2) double-acting piston type: 3.9" x 31.9" (100mm x 810mm)	
Steering cylinder	Two (2) double-acting piston type: 2.5" x 14.7" (65mm x 374mm)	
Steering oil pump	Gear type: 27.7 GPM/996psi @2200 RPM (105 LPM/70kg/cm <sup>2</sup> @2200 RPM)	
Main oil pump	Gear type: 16.1 GPM/996psi @2200 RPM (61 LPM/70kg/cm <sup>2</sup> @2200 RPM)	
Pilot oil pump	Gear type: 12.7 GPM/996psi @2200 RPM (48 LPM/70kg/cm <sup>2</sup> @2200 RPM)	
Relief valve set pressure	Loading	3000 psi (210 kg/cm <sup>2</sup> )
	Steering	3000 psi (210 kg/cm <sup>2</sup> )
HYDRAULIC CYCLE TIME*		
Lifting time (at full load)	5.8 sec.	
Lowering time (empty)	2.9 sec.	
Bucket dumping time	2.2 sec.	
TOTAL	10.9 sec.	

\* Measured in accordance with SAE J732C

AXLE SYSTEM		
Drive system	4-wheel drive	
Front and rear axle	Semi-floating type	
Tires	Standard	20.5 x 25-12PR (L-2)
	Optional	17.5 x 25-12PR (L-3) 20.5 x 25-12PR (L-3)
Reduction and differential gear	Spiral bevel/gear, 1 stage reduction, torque proportioning type	
Final reduction gear	Internal planetary gear (5.625:1) inboard mounted	
Oscillation angle	±12° (total 24°)	

BRAKE SYSTEM	
Service brakes	4-wheel enclosed wet disc brakes, dual circuit
Parking/Emergency brake	Spring applied oil pressure released type, located on drive shaft. Meets MSHA requirements

## WEIGHTS AND DIMENSIONS (SUPPLEMENTAL DATA)

		Operating Weight	Tipping Load			Overall Width (Outside Tire)	Tread	Vertical Dimensions	Overall Length
			Straight	Full Turn					
ROPS Canopy (Instead of ROPS Cab)	lb (kg)	-310 (-140)	-285 (-130)	-255 (-115)	in (mm)				
Tires: 17.5-25-12PR (L-2)	lb (kg)	-795 (-360)	-520 (-235)	-440 (-200)	in (mm)	-1 <sup>3</sup> / <sub>16</sub> " (-30)	+2 <sup>3</sup> / <sub>8</sub> " (+60)	-2 <sup>3</sup> / <sub>4</sub> " (-70)	+2 <sup>3</sup> / <sub>4</sub> " (+70)
20.5-25-12PR (L-3)	lb (kg)	+265 (+120)	+175 (+80)	+140 (+65)	in (mm)				
Air conditioner (deletion)	lb (kg)	-220 (-100)	-265 (-120)	-220 (-100)	in				
Belly Guard (rear frame)	lb (kg)	+240 (+110)	+310 (+140)	+270 (+120)	in				

Base Tire 20.5-25-12PR (L-2)

Tread . . . . . 6'1<sup>5</sup>/<sub>8</sub>" (1870mm)  
 Width (outside tire) . . . . . 7'10<sup>11</sup>/<sub>16</sub>" (2405mm)  
 Width (outside bucket) . . . . . 8'7<sup>7</sup>/<sub>16</sub>" (2450mm)  
 Equipped with GSC bucket with bolt on cutting edge  
 20.5-25-12PR (L-2) Tire and ROPS Cab

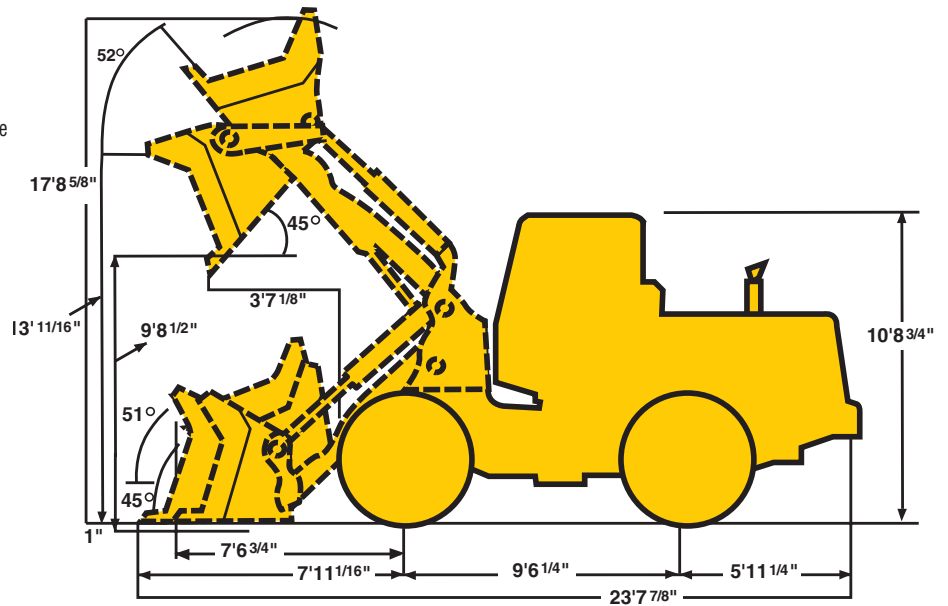

## BUCKET DATA

### General Purpose Bucket

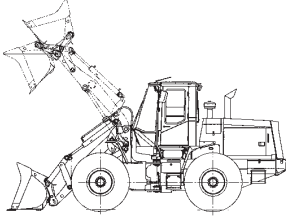
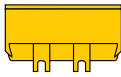
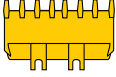
			General Purpose	
			With Bolt-on Cutting Edge	With Teeth
				
Capacity	Heaped	yd <sup>3</sup> (m <sup>3</sup> )	2.8 (2.1)	2.6 (2.0)
	Struck	yd <sup>3</sup> (m <sup>3</sup> )	2.3 (1.7)	2.2 (1.6)
Maximum dumping clearance		ft-in (mm)	9'8 <sup>5</sup> / <sub>8</sub> " (2950)	9'5" (2870)
Dumping reach (to front of bucket edge or tooth)		ft-in (mm)	3'7 <sup>1</sup> / <sub>8</sub> " (1095)	3'9 <sup>1</sup> / <sub>4</sub> " (1150)
Bucket hinge pin height		ft-in (mm)	13 <sup>11</sup> / <sub>16</sub> " (3980)	13 <sup>11</sup> / <sub>16</sub> " (3980)
Digging depth		ft-in (mm)	1" (25)	1 <sup>9</sup> / <sub>16</sub> " (40)
Breakout force		lb (kg)	24,100 (10,930)	25,530 (11,580)
Bucket tilt-back angle	at ground level		45°	45°
	at carry position		51°	51°
Overall	Length	ft-in (mm)	23'7 <sup>7</sup> / <sub>8</sub> " (7210)	23'11 <sup>13</sup> / <sub>16</sub> " (7310)
	Height	ft-in (mm)	10'8 <sup>3</sup> / <sub>4</sub> " (3270)	10'8 <sup>3</sup> / <sub>4</sub> " (3270)
	Width (outside tire)	ft-in (mm)	7'10 <sup>1</sup> / <sub>16</sub> " (2405)	7'10 <sup>1</sup> / <sub>16</sub> " (2405)
	Width (outside bucket)	ft-in (mm)	8 <sup>17</sup> / <sub>16</sub> " (2450)	8 <sup>17</sup> / <sub>16</sub> " (2450)
Wheel base		ft-in (mm)	9'6 <sup>1</sup> / <sub>4</sub> " (2900)	9'6 <sup>1</sup> / <sub>4</sub> " (2900)
Minimum turning radius	at outside bucket	ft-in (mm)	18'8 <sup>3</sup> / <sub>16</sub> " (5695)	18'9 <sup>3</sup> / <sub>8</sub> " (5725)
	at center of outside tire	ft-in (mm)	16'1 <sup>1</sup> / <sub>16</sub> " (4920)	16'1 <sup>1</sup> / <sub>16</sub> " (4920)
Minimum ground clearance		ft-in (mm)	1'5 <sup>1</sup> / <sub>2</sub> " (445)	1'5 <sup>1</sup> / <sub>2</sub> " (445)
Full articulation angle		degree	40°	40°
Operating weight (with ROPS Cab)		lb (kg)	26,410 (11,980)	26,320 (11,940)
Static tipping load (with ROPS Cab)	Straight	lb (kg)	18,170 (8240)	18,300 (8300)
	Full turn	lb (kg)	15,560 (7060)	15,680 (7110)

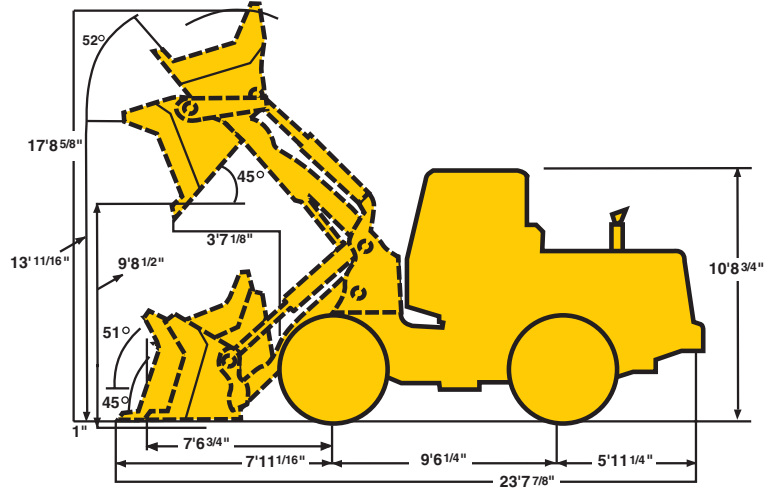

The weight and load figure includes counterweight, air conditioner, enclosed ROPS cab, hydraulic coupler, 20.5-25-12PR (L-2) tires, full fuel tank and operator.

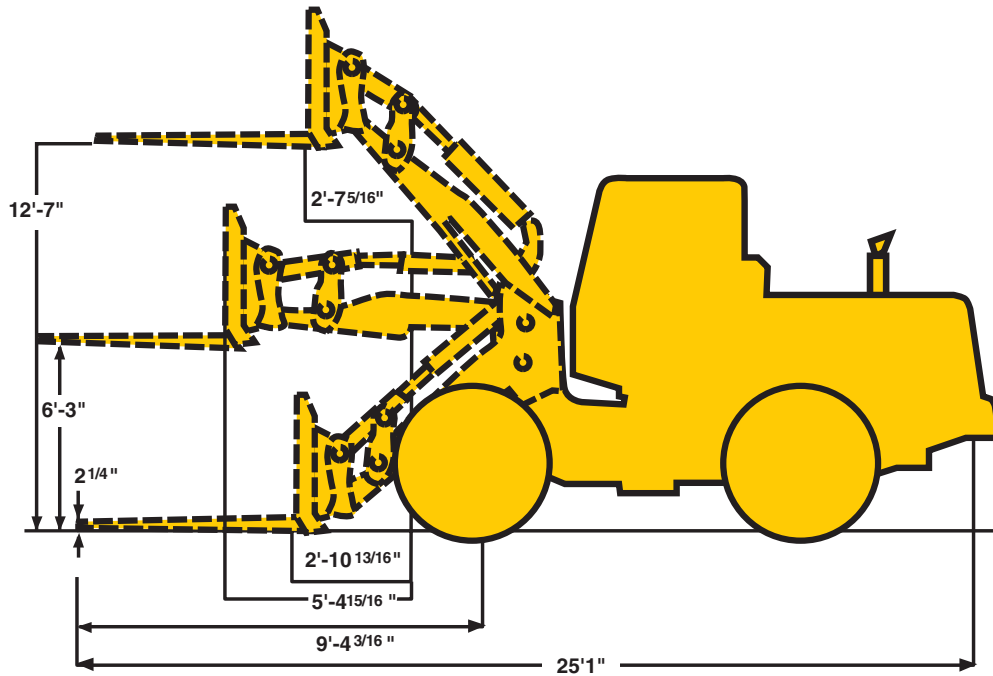

### Construction Utility Fork

SPECIFICATIONS WITH FORKS			
Fork Tine length		48"	60"
Ground to top of tine clearance	ft-in (mm)	12'7" (3835)	12'7" (3835)
Reach with arms horizontal and forks level	ft-in (mm)	9'5" (2870)	10'5" (3175)
Overall Length	ft-in (mm)	25'1 <sup>3</sup> / <sub>16</sub> " (7650)	26'1" (7950)
Static tipping load with level arms and forks, load center <b>straight</b>	lb (kg)	13,600 (6170)	12,830 (5820)
Static tipping load with level arms and forks, load center <b>full 40° turn</b>	lb (kg)	11,660 (5290)	11,000 (4990)
Operating weight*	lb (kg)	26,060 (11,820)	26,150 (11,860)
Attachment weight with 60" carriage	lb (kg)	1475 (670)	1571 (713)

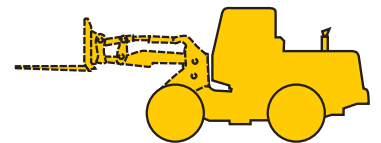
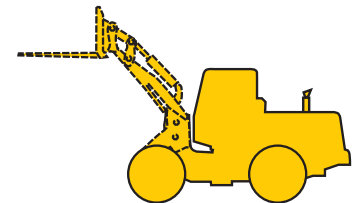

The weight and load figure includes counterweight, air conditioner, enclosed ROPS cab, hydraulic coupler, 20.5-25-12PR (L-2) tires, full fuel tank and operator.

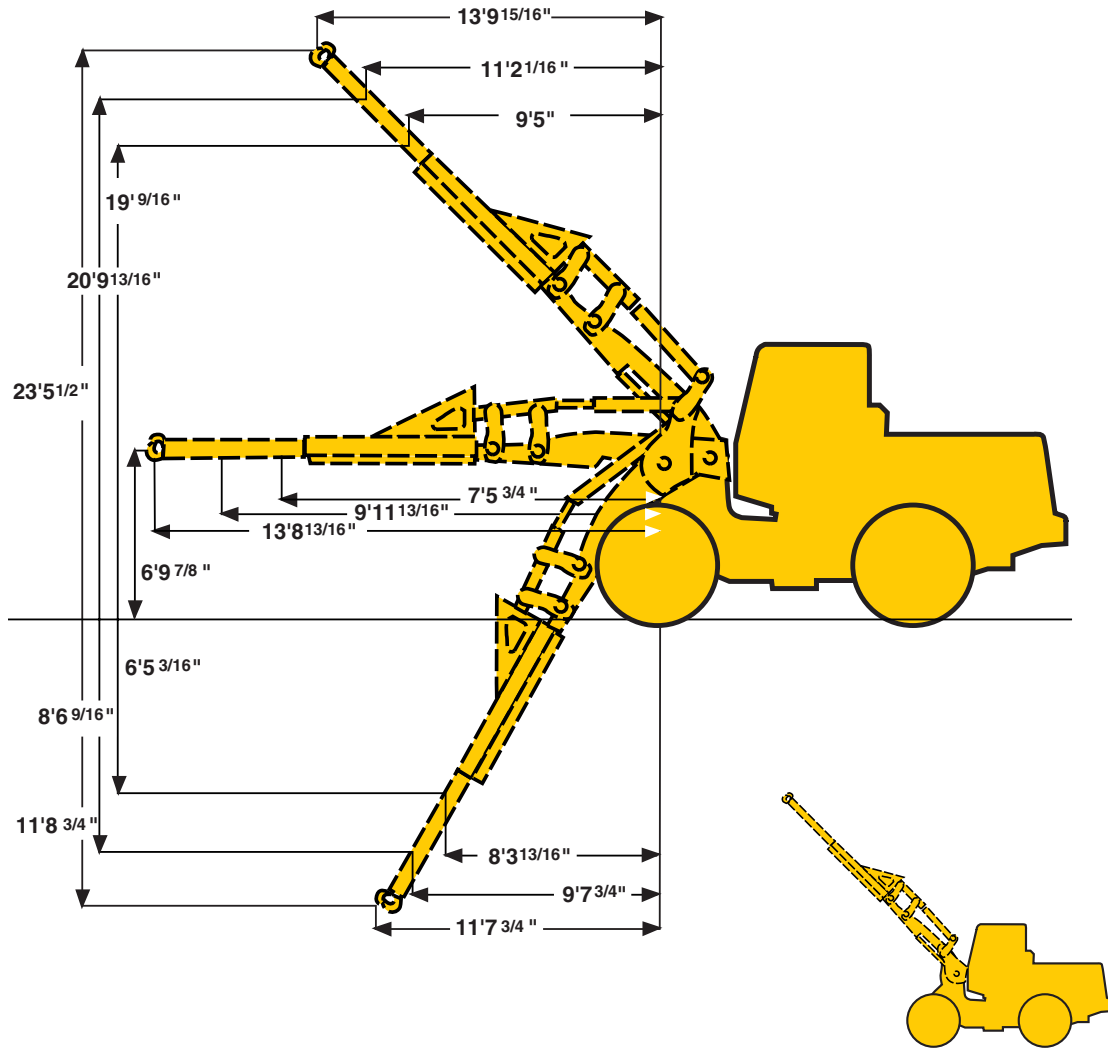

### Extendable Boom

#### SPECIFICATIONS WITH EXTENDABLE BOOM

Boom position		Retracted	Mid-Position	Extended
Operating load at 40° articulation	lb (kg)	3791 (1720)	3229 (1465)	2788 (1265)
Static tipping load*	Full 40° turn	lb (kg)	6459 (2930)	5577 (2530)
	Straight	lb (kg)	7539 (3420)	6525 (2960)
Operating weight*	lb (kg)	25,463 (11,550)	25,463 (11,550)	25,463 (11,550)
Attachment weight	lb (kg)	1107 (502)	1107 (502)	1107 (502)

The weight and load figure includes counterweight, air conditioner, enclosed ROPS cab, hydraulic coupler, 20.5-25-12PR (L-2) tires, full fuel tank and operator.

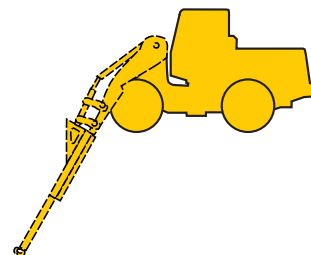
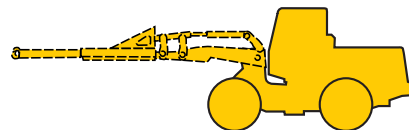

### STANDARD EQUIPMENT

<p>Air Cleaner (Double Element Donaldson) with PreCleaner</p> <p>Alarms (Audible): Brake Oil Pressure Engine Oil Pressure</p> <p>Alarms (Visual): Air Filter Battery Discharge Brake Oil Pressure Converter Oil Temperature Engine Oil Pressure Engine Coolant Temperature Parking Brake</p> <p>Alternator (50 amp)</p> <p>AM/FM Cassette Radio</p> <p>Batteries: 12V-110AH (2 units)</p> <p>Bellyguard, Engine</p> <p>Brake Line Protection (Front)</p> <p>Brake (Parking) Spring applied; Oil pressure released, Drum type</p> <p>Brakes (Service)</p>	<p>Enclosed Wet Disc, Dual System</p> <p>Full Hydraulic System</p> <p>Bucket Control Lever, Single (Pilot Assisted)</p> <p>Bucket Leveler</p> <p>Boom Kickout</p> <p>Coat Hook</p> <p>Cold Start Aid</p> <p>Converter, 12V/10Amp dash outlet</p> <p>Counterweight, Bucket</p> <p>Coupler Hydraulics w/ Line &amp; Controls</p> <p>Cup Holder</p> <p>Downshift Button</p> <p>Drawbar</p> <p>Electrical System (24 volt)</p> <p>Fan, Hydraulic (Blower)</p> <p>Fenders (Front and Rear)</p> <p>Gauges: Converter Oil Temperature Engine Coolant Temperature Fuel Level Hour Meter</p>	<p>Hydraulic Oil Level Tachometer</p> <p>Heater/Pressurizer (40,000 BTU)</p> <p>Hoodsides (Hinged)</p> <p>Horn (Electric)</p> <p>Indicators: High Beam Parking Brake Transmission Declutch Transmission Shift Monitor Working Light</p> <p>Linkage (Parallelogram)</p> <p>Lights: Headlights (2) Halogen Working Lights 4 front 4 Rear 2 Stop/Tail 2 Backup</p> <p>Muffler</p> <p>Neutral Safety Start</p> <p>Operator's Manual Box</p> <p>Radiator: Heavy Duty Plate Fin Type</p> <p>Radiator Grille</p>	<p>Reverse Alarm</p> <p>ROPS Cab: Enclosed cab with sound suppression, front lights, front and rear wipers and washers, one rear view and two side mirrors, tinted glass, slide down windows, and rear lights</p> <p>Safety Articulation Locking Bar</p> <p>Seat, Air Ride</p> <p>Seat Belt, Retractable, 3" wide</p> <p>Shift Control Unit for Automatic Shift</p> <p>Single Lever Hydraulic Control</p> <p>Telescopic and Tilt Steering Wheel</p> <p>Torque Proportioning Differentials</p> <p>Transmission Declutch Selector Switch</p> <p>Vandalism Protection</p> <p>Wrist Rest, Adjustable</p>
--	---	---	--

### OPTIONAL EQUIPMENT

<p>Air Conditioner (R134) Refrigerant</p> <p>Belly Guard</p> <p>Bolt-on Cutting Edge Segments</p> <p>Bucket Teeth</p>	<p>Cushion Dump Valve</p> <p>Dual Lever Hydraulic Control</p> <p>Emergency Steering Hydraulic System, 3 Spool Valve</p>	<p>K-LINK</p> <p>No Spin Differential</p> <p>Quick Coupler &amp; Attachments</p> <p>Radiator, Wide Fin Spacing</p>	<p>Ride Control</p> <p>ROPS Canopy</p> <p>Turn Signal With Four-Way Flasher</p>
---	---	--	---

### BUCKET SELECTION CHARTS

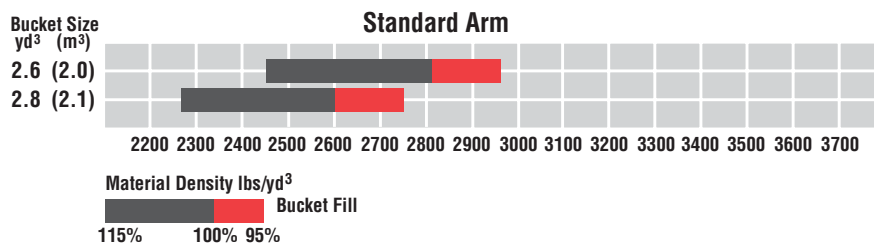

# KAWASAKI LOADERS

*More Than A Machine, A Complete Solution*

Kawasaki Construction Machinery Corp. of America, a division of Kawasaki Heavy Industries, is a leading supplier of a full range of high quality wheel loaders. In fact, Kawasaki is the oldest on-going manufacturer of articulated, rubber-tired wheel loaders in the world. Since 1962, Kawasaki wheel loaders have continuously evolved to bring you the best in equipment and support services, backed by a carefully selected dealer network.

Kawasaki articulated wheel loaders incorporate innovative design features coupled with extensive knowledge and experience gained from real-world applications. Kawasaki pioneered Z-Link design to provide unmatched utility, high breakout force and efficiency in its machines. Powered by proven emissions-compliant Cummins diesel engines, durability and serviceability are designed into every Kawasaki loader.

Kawasaki loaders are assembled at the company's modern facilities in Newnan, GA. Service and support operations are headquartered in Kennesaw, GA.

A state-of-the-art parts distribution system links dealers with the main parts warehouse, allowing them to order parts directly. Qualified craftsmen rebuild components for all Kawasaki models at our fully-equipped rebuild center, making component exchange easier and

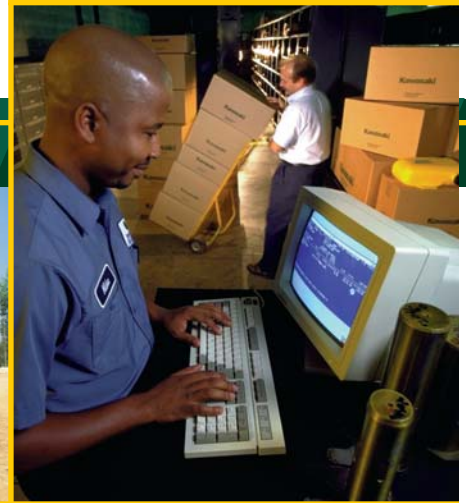

faster. An independent oil analysis program allows monitoring of critical systems to reduce unscheduled downtime.

The independent dealers that represent and support Kawasaki loaders are

experts in their markets and are dedicated to providing you with the best service available. Together, we are committed to making your investment in a Kawasaki loader a sound business decision that will pay dividends for years to come.



2140 Barrett Park Drive • Suite 101  
Kennesaw, Georgia 30144  
Tel: 770-499-7000 • Fax: 770-421-6842  
[www.kawasakiloaders.com](http://www.kawasakiloaders.com)

